

Geocontrol PRO

Installation and Operation Manual



Table of Contents

DOCUMENTATION CONVENTIONS	1
NOTICES	1
Chapter 1: System Description.....	3
Chapter 2: System Installation	4
Chapter 3: System Operation.....	5
Chapter 4: System Maintenance.....	7
Chapter 5: System Troubleshooting	10
Chapter 6: System Specifications	12
Chapter 8: Replacement Parts List	15
NOTES.....	18
EC Declaration of Conformity	19
THE WARRANTY.....	20
Equipment Return Policy.....	20
Equipment Decontamination.....	20

DOCUMENTATION CONVENTIONS

This manual uses the following conventions to present information:



An exclamation point icon indicates a **WARNING** of a situation or condition that could lead to personal injury or death. You should not proceed until you read and thoroughly understand the **WARNING** message.



A raised hand icon indicates **CAUTION** information that relates to a situation or condition that could lead to equipment malfunction or damage. You should not proceed until you read and thoroughly understand the **CAUTION** message.



A note icon indicates **NOTE** information. Notes provide additional or supplementary information about an activity or concept.

NOTICES



In order to ensure that your Controller has a long service life and operates properly, adhere to the cautions below and read this manual before use.

Disconnect from power source when not in use.

Controller power input source must not exceed maximum ratings.

Controller must be wired to a negative ground system.

Controller may not operate properly with excess wiring not supplied by manufacturer.

Avoid spraying fluid directly at controller.

Never submerge controller.

Avoid pulling on wires to unplug controller wiring.

Avoid using controller with obvious physical damage.

To prevent controller damage, avoid dropping controller.



NOTE

The Geotech Geocontrol PRO cannot be made dangerous or unsafe as a result of failure due to EMC interference.



WARNING

Do not operate this equipment if it has visible signs of significant physical damage other than normal wear and tear.

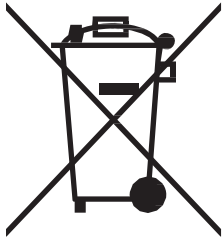

Notice for consumers in Europe:

This symbol indicates that this product is to be collected separately.

The following apply only to users in European countries:

- This product is designated for separate collection at an appropriate collection point. Do not dispose of as household waste.
- For more information, contact the seller or the local authorities in charge of waste management.

Chapter 1: System Description

Function and Theory

The Geocontrol PRO is a unique controller for operating down well bladder type sampling pumps. When an external 12 VDC power source is connected to the controller, the internal air compressor is capable of producing a pressure of 100 PSI (7 bar). This pressure allows the user to take samples from a depth to 180 feet (55 mm).

The controller offers a variable cycle timer for controlling the portable compressor's on-time and off-time. While the compressor is on, air is pushed down well to the bladder pump, compressing the internal bladder and evacuating the liquid in the pump. When the compressor shuts off, the air pressure in the pump exhausts out of the system, allowing liquids to enter the pump.

Chapter 2: System Installation



WARNING

Verify the 12V system to be used is rated and fuse protected for operation at 15 amps continuous operation. Failure to verify system rating could result in damage to equipment. Over-heated wiring and other materials or components in contact or near by the power delivery system could pose a potential fire or burn hazard.

To operate the Geocontrol PRO, make sure the power switch is in the “off “position (rocker in down position). Plug the power input cord into a fuse protected 12V lighter receptacle on a negatively grounded system. If the controller is to be wired directly to a 12V battery, make sure to connect the positive (red) alligator clip to the positive (red) battery terminal and connect the negative (black) alligator clip to the negative (black) battery terminal. Next, securely plug in the circular plug connector on the opposite end of the cable to the corresponding receptacle on the face of the controller. Continue by plugging the pump’s air hose into the port labeled AIR on the controller’s face. Then plumb the pump’s discharge line into a suitable container. Check all wiring and plumbing for correctness.

Finally, double check to ensure the 12V system positive and negative is not reversed at any connection point.

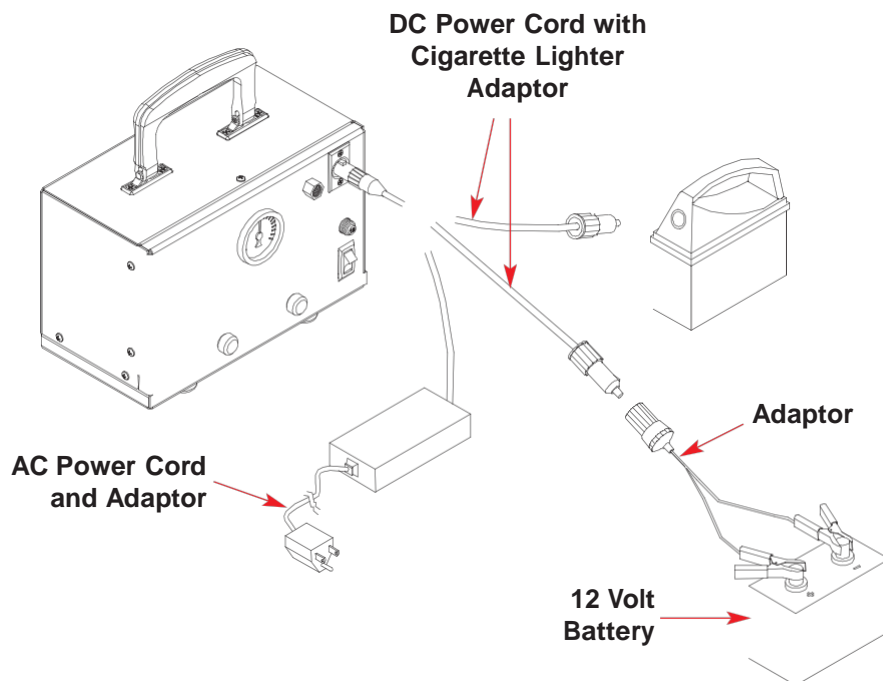

Figure 1
Installation Diagram

Chapter 3: System Operation



WARNING

Do not operate this equipment if it has visible signs of significant physical damage other than normal wear and tear.



CAUTION

Operating the equipment in any way other than that described within this document could potentially damage the equipment.

Disconnect power source when not in use.

Double check 12V systems positive and negative are not reversed at any connection point.

Before turning the power switch “on” turn the Geocontrol PRO’s “Fill” and “Discharge” timer knobs to adjust the cycle times. These knobs are located on the front face of the Geocontrol PRO below the airline pressure gauge. To the left is Discharge time and to the right is Fill time. Use the radial number scales around each timer knob to adjust timer values in seconds.

Discharge Time:

The time it takes to squeeze the bladder and push the water out of the pump. Increase this time with increased depth to water and larger bladder pumps. Decrease this time with lower depth to water and smaller bladder pumps. Timer can be set from approximately 2 to 60 sec.

Fill Time:

The time allowed for the bladder to refill. Increase this time with increased depth to water and larger bladder pumps. Decrease this time with lower depth to water and smaller bladder pumps. Timer can be set from approximately 2 to 60 seconds. Fill rate depends on hydrostatic pressure (pressure from the water above the pump) and will vary depending on pump placement within the water column. Therefore, the more water above the pump the faster it will fill.

Turn the controller power switch ON. In case of long fluid discharge lines it could take multiple cycles for water to reach the outlet. If the fluid discharge from the pump falls off before the discharge cycle is complete, the discharge time is set too high. This could result in a creased bladder that will reduce per cycle pump volumes. Therefore, if the compressor is still running and water has stopped coming out of the discharge tube, the discharge time should be decreased. Pumping efficiency can be maximized by measuring the amount of fluid discharged. If the volume of fluid after one pump cycle is less than the rated volume of the pump being used, then the fill rate can be increased.

The air line pressure gauge can be utilized to maximize efficiency. As a general rule, the pressure indicated on the gauge should not exceed an equivalent depth to water pressure. 1 PSI = 2.31 feet (1 bar=1.02 m) of water. Once the bladder in the pump is empty of liquids the pressure will increase sharply. If a quick pressure increase is noticed, reduce the discharge time until the quick pressure increase is no longer obvious.

For example, if the well you are sampling has a depth to water of 23 feet (7 m) you should not expect to see a reading on the pressure gauge much over 10 PSI (.7 bar). When the discharge cycle begins the reading on the pressure gauge will begin to rise. Once depth to water pressure has been reached the reading will 'stall' at that pressure until the bladder is empty or discharged. Once the bladder is compressed completely the pressure will again start to rise. For maximum per cycle liquid pumping volume, this is the optimum point at which the discharge timer would expire and the fill rate timer would begin. Reduced per cycle liquid pumping volume can be achieved by further decreasing the discharge time, thus evacuating only part of the total bladder volume.



CAUTION

For use with negative (-) ground systems only.
Exceeding the recommended duty cycle will cause overheating.
Damage will result if the supply voltage exceeds 14 VDC.

Chapter 4: System Maintenance

Maintenance Procedures

Disconnect power source when not in use.

Unit must be returned to Geotech Environmental Equipment for any service. In order to ensure a long service life, keep the Geocontrol PRO clean. Often a soft, damp cloth can be used to remove dust and dirt from the exterior surfaces of the Geocontrol PRO. In extreme cases, or to remove aged caked on dirt and dust, a mild soap and water solution can be applied to a soft cloth and used to clean the exterior surfaces of the Geocontrol PRO. Do not soak or directly spray liquids on the Geocontrol PRO.



WARNING

Equipment should be repaired by Geotech Environmental Equipment factory trained repair technicians only. Improper repair of equipment may result in degradation of performance and/or service life. Disassembly exposes potentially dangerous moving components that could injure someone who is not properly trained to repair this equipment.

Solenoid Maintenance

The following procedure outlines how to remove, dis-assemble and clean a stuck or clogged breather vents on the solenoid.

- If you have brass breather vents and would like to replace them with the newer version of stainless steel breather vents, contact Geotech Environmental Equipment and reference part # 11150333.
- Note: The space that you will be working in will be pretty tight, so you will might need to use needle nose pliers to disassemble and reassemble the solenoid.
- Tools needed: Phillips head screwdriver
1/4" wrench
7/16" wrench
Needle nose pliers

Steps:

1. Unplug unit.
2. Remove clear tubing that connects to the compressor and the air pressure gage. Note that you should not remove this tubing at the connections on the solenoid. See Figure 4-1.



Figure 4-1

3. Remove the two screws that connect the solenoid to the casing. You do not have to disconnect the 3 black wires from the solenoid, they should be long enough to allow you to set the solenoid down on a flat surface for cleaning. See Figure 4-2.

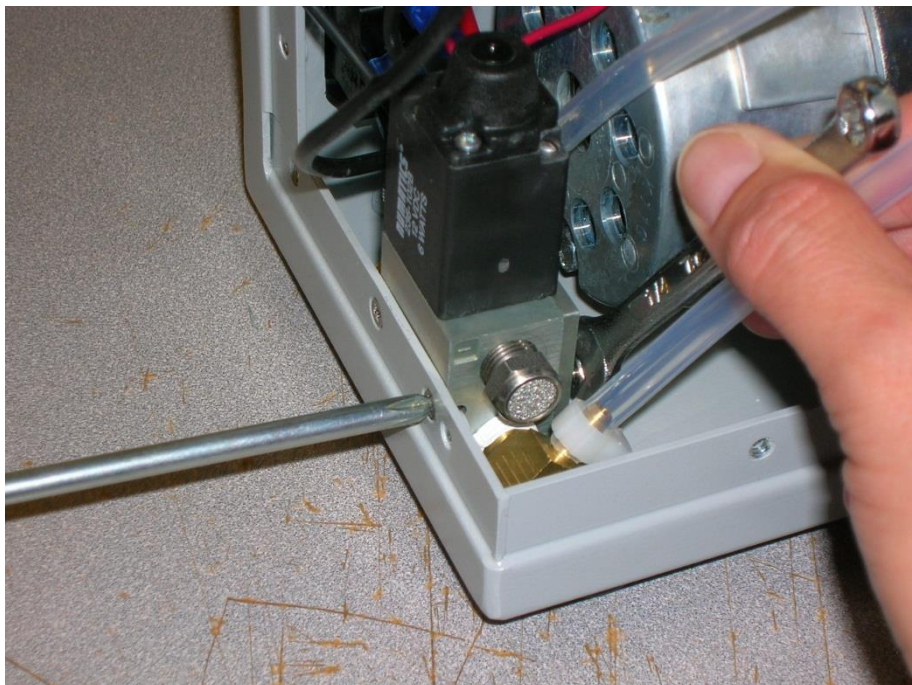

Figure 4-2

4. Unscrew the breather vents from the solenoid using a 7/16" wrench. See Figure 4-3.

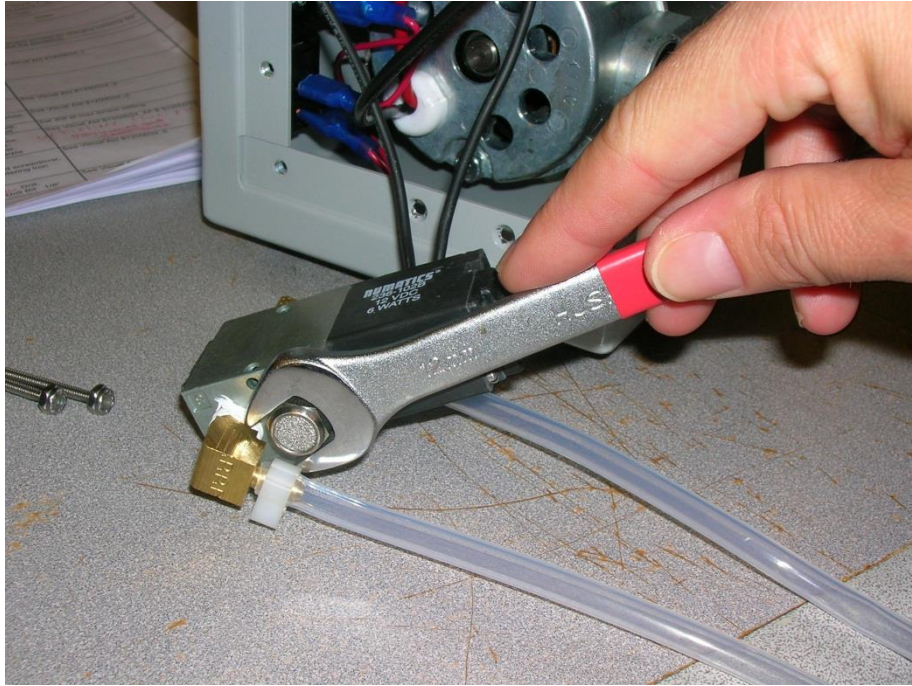

Figure 4-3

5. Clean breather vents with water. Do NOT use alcohol!
6. After cleaning is complete, put the breather vents back on the solenoid. Be sure they are tightened.
7. Attach the solenoid back to the casing using a 1/4" nut driver. Be sure that the clear tubing is pointing toward the compressor (right side).
8. Attach the tubing back to the compressor and the air pressure gage. Note that the longest piece of tubing attaches to the compressor.

If you need further assistance or want to replace the breather screens call Geotech Service at 1-800-833-7958.

Chapter 5: System Troubleshooting

The Geocontrol PRO has been designed and manufactured to provide a long service life and trouble free operation in the field. If the compressor, during charge cycles, becomes sluggish, check supply voltage. If the supply voltage falls below 12 VDC, the compressor's performance will be directly affected. A fully charged battery will produce the best results.

Other sources of low pump output may be 12V lighter receptacles or plugs. Make certain these connections are securely plugged in and clear of any debris. Once securely plugged in, rotating the connection can often help if there is a dead spot in the connector. Also, check for connection and cable fatigue, cracks, surface oxidation, rust etc.

If the compressor does not turn on:

- Double check battery polarity is correct. In other words, the positive and negative cables are connected positive to positive and negative to negative. The Geocontrol PRO is protected from damage due to reverse polarity connection.
- Turn the power switch to the OFF position and let the unit sit in the OFF state for two minutes. This will hard reset the electronic timer module.
- If ambient temperatures are in excess of 104°F (~40°C) then disconnect from power and let sit in a cool location. Do not open the case for any reason. This will not hasten the cooling process, but will invite debris into internal components that could result in reduced life or immediate equipment failure.
- If the compressor still does not turn on the electronic timer module may have failed. Call Geotech Service at 1-800-833-7958 to arrange for the equipment to be sent back to a factory authorized repair location.
- If 15 Amp circuit breaker is tripped, push to reset. If it trips again, call Geotech Service at 1-800-833-7958 to arrange the equipment to be sent back to a factory authorized repair location.

Compressor turns on and fluid is being pumped but no pressure is indicated on the gauge.

- The pressure gauge has failed; however operation of the device may continue even though the gauge feature is not operational. Call Geotech Service at 1-800-833-7958 to arrange for the equipment to be sent back to a factory authorized repair location.

Fluid is not being pumped and the compressor turns on, no pressure is indicated on the gauge.

- Remove the air line from the front of the Geocontrol PRO. Block the air outlet on the front of the Geocontrol PRO while the compressor is running to verify the pressure gauge needle indicates an increase in pressure. Remove the blockage from the air outlet and observe whether or not a small burst of compressed air is released. If pressure cannot be built at the outlet on the front of the Geocontrol PRO, call Geotech Service at 1-800-833-7958 to arrange for the equipment to be sent back to a factory authorized repair location.
- If pressure can be built at the air outlet on the front of the Geocontrol PRO while the compressor is running:

- 1) Attach the air line only and block the end. Verify the pressure gauge needle indicates an increase in pressure. Remove the blockage from the end of the air line and observe whether or not a small burst of compressed air is released. If pressure cannot be built at the end of the air line, check the air line for cuts, kinks and holes, especially at, and near, the bladder pump hose barb or compression fitting connections.
- If pressure can be built at the end of the air line while the compressor is running:
 - 1) Attach the air line to the bladder pump. Remove the fluid discharge tube from the bladder pump. While the compressor is running, very little air discharge should be felt at the pump discharge fitting. The pressure gauge on the front of the Geocontrol PRO should indicate a rise in pressure. If this does not occur and a continuous air flow can still be felt at the pump fluid discharge fitting, then the bladder, or bladder seal, has been compromised and should be repaired or replaced. Information on this procedure can be found in the product manual specific to the bladder pump being used. Or call Geotech Service at 1-800-833-7958 for further assistance.
 - 2) **Reminder:** Be careful not to over pressurize and crease the bladder inside the pump as this will reduce the fluid flow during normal operation.

Chapter 6: System Specifications

Power Requirements:	72-84 W 12-14 VDC input at 7.5 Amps
Nominal Operating Current:	6 Amps DC
Over Current Protection:	15 Amps
Timer: Discharge Time Fill Time	1.8 sec. min. – 60 sec. max. 1.8 sec. min. – 60 sec. max. (+/- .25% repeatability)
Maximum Operating Depth:	180 ft. (55 m)
Maximum Operating Pressure:	100 PSI (7 bar) (self limited for safety) @ 0.83 CFM (1.41 m ³ /h)
Ambient Operational Temperature:	50°F-104°F (10°C-40°C)
Dimensions:	6.70" H x 4.80" x 11.40" W (17.02cm H x 12.92cm D x 28.96cm W)
Weight:	9 lbs. (4 kg) total

Features

- Variable pump Discharge time control.
- Variable pump Fill time control.
- Interchangeable pump connection configurations.
- Operation with dedicated pump systems and special purpose well caps.
- Approx. 45 to 60 minute operation with 8.0Ah lead acid battery (Battery Module w/o Charger, Geotech PN: 77250001).
- Reverse polarity protection.
- AC adapter optional for use with world mains connection.

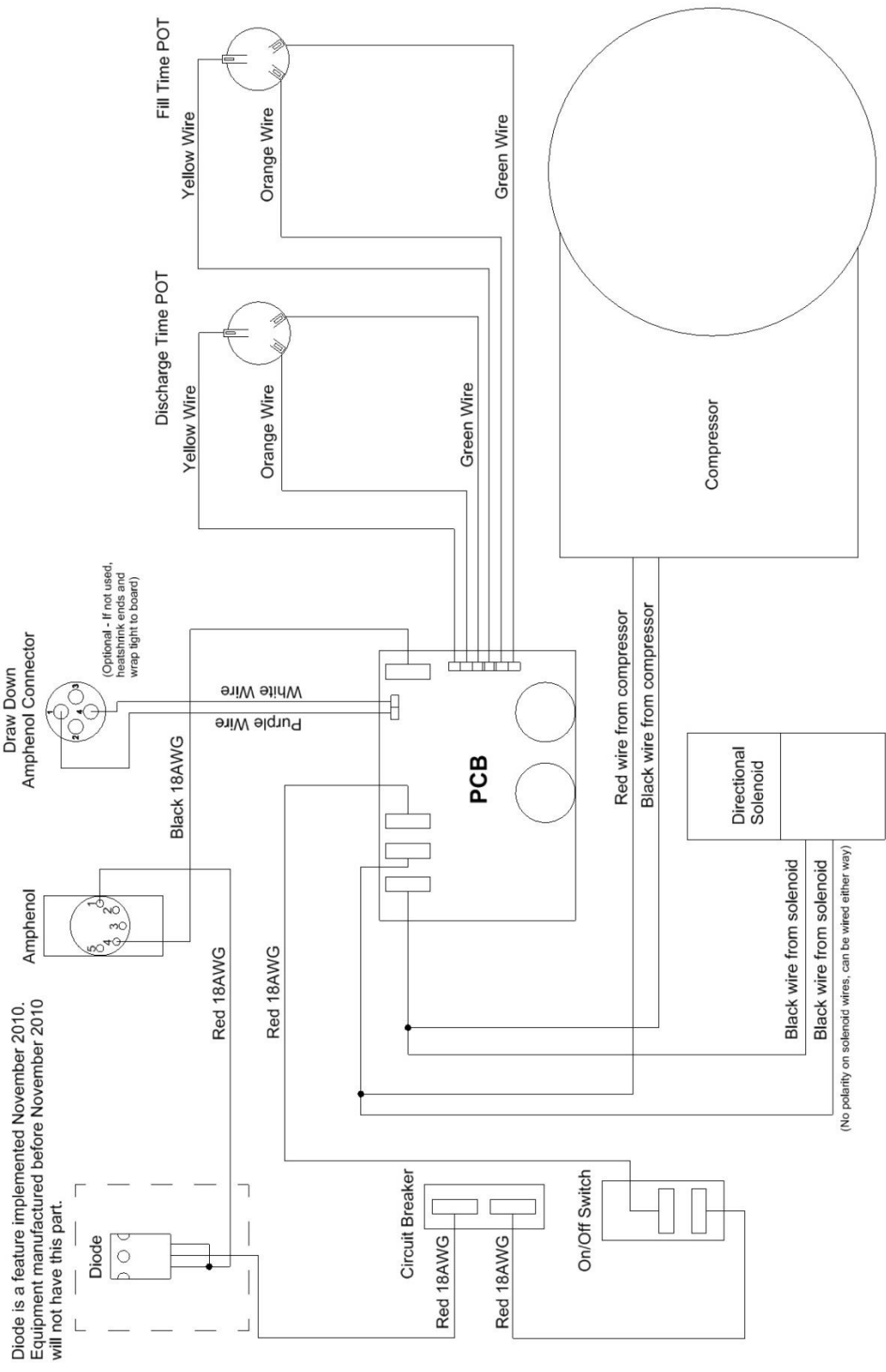

Parts Assembly

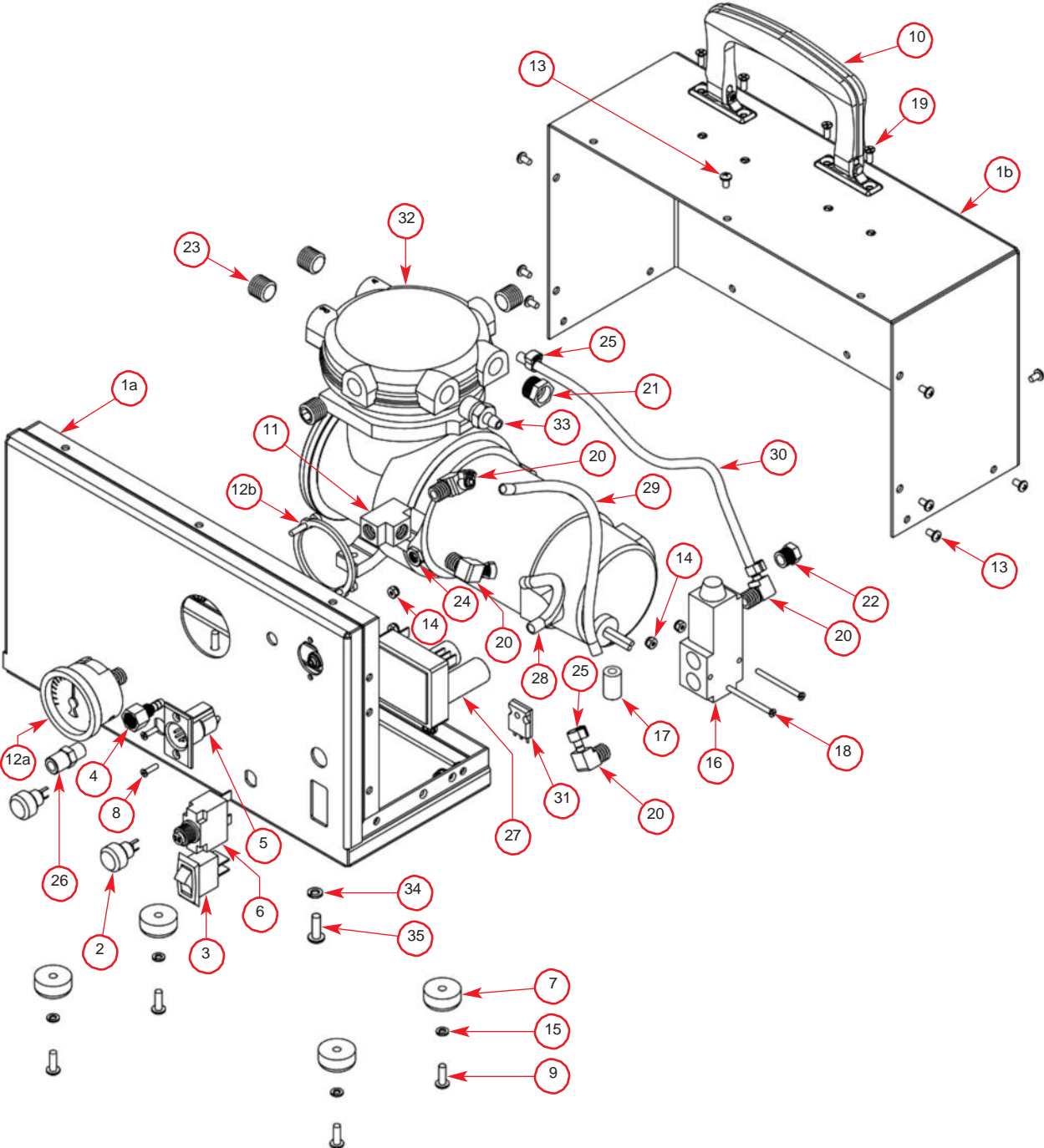

Chapter 8: Replacement Parts List

MODEL GEOCONTROL PRO – 51150122

Item	Qty	Description	Part No.
1a	1	ENCLOSURE, GEOCONTROL PRO, BACK, CE	51150121
1b	1	ENCLOSURE, GEOCONTROL PRO, BACK, CE	51150121
2	2	POT, 10K, 20% W/KNOB	11150244
3	1	SWITCH, GEOCONTROL PRO	11150248
4	1	HOSEBARB, SS4, BLKHD, .170 X 1/8"	21150021
5	1	CONN, AMP, MALE, PANEL MOUNT	17200014
6	1	CIRCUIT BREAKER, 15AMP GEOCONTROL PRO	11150247
7	4	FOOT, RUBBER, 7/8", W/WASHER	11150262
8	2	SCREW, SS8, 4-40 X 7/16" FH PHIL	16700007
9	4	SCREW SS8, 8-32 X .5", PNH	PPF036001
10	1	HANDLE, PE, NI	11350009
11	1	TEE, BRS, 1/8" NPT, FXFXF	PPP047034
12a	1	GAUGE, PANEL MOUNT, 1-100PSI W/MOUNTING CLAMP	11150254
12b	1	GAUGE, PANEL MOUNT, 1-100PSI W/MOUNTING CLAMP	11150254
13	14	SCREW, SS8, 6-32 X .25", PNH, M/S	17200078
14	4	NUT, HEX, 4-40, NYLOC	17200046
15	4	WASHER, SS8, #8, LOCK	17200081
16	1	SOLENOID, GEOCONTROL PRO	11150249
17	1	STANDOFF, NYL, .187 X .437 X .375	17500355
18	2	SCREW, SS8, 4-40 X 1.25", FLHD	PPF051015
19	4	SCREW, SS8, 6-32 X 3/8", FLH	PPF013034
20	4	HOSEBARB, BRS, 90D.170 X 1/8MPT	17200393
21	1	VENT, BREATHER, 1/4" NPT	11150252
22	2	VENT, BREATHER, 1/8" NPT	11150333
23	4	PLUG, BRS, 1/4"NPT, SOCKET	11150251
24	1	NUT, SS8, 5/16-32, HEX, THIN	11150261
25	5	CLAMP, NYL, 1/4" SNAPPER	11150259
26	1	QCK CNCT, NCKL, 1/4" X 1/8MPT, PUSH/PULL	PPP103001
27	1	ASSY, PCB, GEOCONTROL PRO POTTED	51150054
28	1	TUBING ,FEP, .170 X 1/4, FT FEP	87050509
29	1	TUBING ,FEP, .170 X 1/4, FT FEP	87050509
30	1	TUBING ,FEP, .170 X 1/4, FT FEP	87050509
31	1	DIODE, SCHOTTKY, 100V, 40A, TO-247AC	16550223
32	1	COMPRESSOR, PRO, SIPPER	11150325
33	1	HOSEBARB, BRS, .170 X 1/4MPT	16550032
34	3	WASHER, SS8, #10, LOCK	PPF022003
35	3	SCREW, SS8, 10-32 X 5/8", PNH	PPF037008
N/S	1	WASHER, SS410, 5/16", INTRNL TOOTH	17500339

N/S = Not Shown

Accessories

Description	Part No.
GEOCONTROL PRO W/CASE, 1.66, CE, PUMP, 12VDC CORD, BATTERY W/CHRG	91150011
GEOCONTROL PRO W/CASE, .85, CE, PUMP, 12VDC CORD, BATTERY W/CHRG	91150015
GEOCONTROL PRO W/CASE, .675, CE, PUMP, 12VDC CORD, BATTERY W/CHRG	91150016
GEOCONTROL PRO, W/CASE, CE, 12VDC CORD, NO PUMP, NO BATT	91150017
GEOCONTROL PRO, CE, SOLO, CONTROLLER ONLY, NO ACCESSORIES	51150122
POWER SUPPLY, EXTERNAL, AC ADAPT 12V, 100W	51150063
ADAPTOR, CONTROLPRO-WELL CAP INCLUDES 10FT TUBING	81150019
CASE, GEOCONTROL PRO, CE	51150127
ASSY, POWER CORD, DC W/AMP	57500008
ADAPTER, CIGARETTE TO CLIPS	17500035
BATTERY/CHARGER, MODULAR, 12VDC, 7.5Ah, MALE CIG PLUG	77250000
KIT, WLM-BP CONTROLLER LINK LOW DRAW DOWN OPTION	91150001
ASSY, CABLE, WLM, LOGIC UNIT CONT	52050174

Maintenance Accessories

Description	Part No.
REBUILD KIT, COMPRESSOR, SIPPER PRO	11150334
REBUILD KIT, SOLENOID, GEOCONTROL PRO	11150433

DOCUMENT REVISIONS		
EDCF#	DESCRIPTION	REV/DATE
-	Previous Release	10/29/12
1583	Added Compressor Repair Kit to Replacement Parts List. Added Revision History Table - SP	05/24/13
-	Updated back page information, updated EC Declaration of Conformity, added "Maintenance Accessories" under Chapter 8: Replacement Parts List, SP	1/13/15

NOTES



EC Declaration of Conformity

Manufacturer:

Geotech Environmental Equipment, Inc.
2650 E 40th Avenue
Denver, CO 80205

Declares that the following products,

Product Name: Geocontrol PRO

Model(s): 81150012
81150016
81150017
81150018

Year of manufacture: 2010

Conform to the principle safety objectives of 2006/95/EC Low Voltage Directive (LVD) by application of the following standards:

EN 61010-1: 2010

Year of affixation of the CE Marking: 2010

Conform to the protection requirements of 2004/108/EC Electromagnetic Compatibility (EMC) by application of the following standards:

EN 61000-6-1: 2007

EN 61000-6-3: 2012

EN 61326-1: 2013, emissions Class A

EMC conformity established 08/14/2009.

Production control follows the ISO 9001:2008 regulations and includes required safety routine tests.

This declaration issued under the sole responsibility of Geotech Environmental Equipment, Inc.

Joe Leonard
Product Development

Serial number _____



THE WARRANTY

For a period of one (1) year from date of first sale, product is warranted to be free from defects in materials and workmanship. Geotech agrees to repair or replace, at Geotech's option, the portion proving defective, or at our option to refund the purchase price thereof. Geotech will have no warranty obligation if the product is subjected to abnormal operating conditions, accident, abuse, misuse, unauthorized modification, alteration, repair, or replacement of wear parts. User assumes all other risk, if any, including the risk of injury, loss, or damage, direct or consequential, arising out of the use, misuse, or inability to use this product. User agrees to use, maintain and install product in accordance with recommendations and instructions. User is responsible for transportation charges connected to the repair or replacement of product under this warranty.

Equipment Return Policy

A Return Material Authorization number (RMA #) is required prior to return of any equipment to our facilities, please call Geotech Service for appropriate location. An RMA # will be issued upon receipt of your request to return equipment, which should include reasons for the return. Your return shipment to us must have this RMA # clearly marked on the outside of the package. Proof of date of purchase is required for processing of all warranty requests.

This policy applies to both equipment sales and repair orders.

FOR A RETURN MATERIAL AUTHORIZATION, PLEASE CALL OUR SERVICE DEPARTMENT AT
1-800-833-7958

Model Number: _____

Serial Number: _____

Date of Purchase: _____

Equipment Decontamination

Prior to return, all equipment must be thoroughly cleaned and decontaminated. Please make note on RMA form, the use of equipment, contaminants equipment was exposed to, and decontamination solutions/methods used.

Geotech reserves the right to refuse any equipment not properly decontaminated. Geotech may also choose to decontaminate equipment for a fee, which will be applied to the repair order invoice.



Envirotecnicos

Tel: +34 872 080 542

envirotecnicos@envirotecnicos.com

www.envirotecnicos.com

Geotech Environmental Equipment, Inc
2650 East 40th Avenue Denver, Colorado 80205
(303) 320-4764 • (800) 833-7958 • FAX (303) 322-7242
website: www.geotechenv.com